

Workplace design

Grinding/welding table

Geovent grinding/welding table is used when grinding with grinder or welding. The table is designed for catching metal dust and welding smoke as the suction is placed directly in the path of the grinding particles.

The grinding table is available with or without rear panel.

The rear panel is constructed in steel with highly efficient extraction gaps. The rear panel is only available as standard for 02-002 and 02-005.

Dimensions

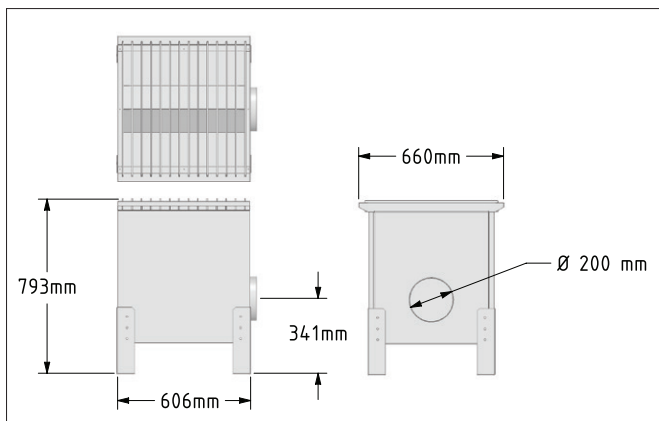

02-002 Welding table.

Ordering table

Art. No.	Description
02-001	Welding table – 600x600x800 mm (WxDxH) Air flow needed: ca. 1.500m ³ /h – connecting piece: ø160 mm
02-002	Welding table – 900x600x800 mm (WxDxH) Air flow needed: ca. 2.000m ³ /h – connecting piece: ø200 mm
02-003	Welding table – 1.200x600x800 mm (WxDxH) Air flow needed: ca. 2.500m ³ /h – connecting piece: ø250 mm
02-005	Welding table – 1.800x1.000x800 mm (WxDxH) Air flow needed: ca. 6.000m ³ /h – connecting piece: ø315 mm
02-006	Welding table – 2.500x800x800 mm (WxDxH) Air flow needed: ca. 6.500m ³ /h – connecting piece: 2xø315 mm (in both ends of the table)

Accessories

Art. No.	Description
02-030	Back draft panel – 900x185x600mm (WxDxH) Air flow needed: ca. 1.000 - 1.500 m ³ /h – connecting piece: ø200 mm with collection drawer
02-037	Corner console for rear edge extraction panel
02-039	Bracket for mounting backdraft extraction on welding table (set of 4 pcs.)



Welding table.



02-002 Welding table.



The rods can easily be moved / changed if needed.